

Printalyzer Enlarging Timer

Version 0.1

Printalizer

Enlarging Timer & Exposure Meter

Table of Contents

Contents:

Introduction	4
Safety Information	5
• Intended Use	
• Symbols	
• Safety Warnings	
Technical Specifications	8
Device Overview	10
• Major Components	
• Front Device Ports	
• Rear Device Ports	
• Button Overview	
Menu Navigation	14
• Main Menu	
• Number Entry	
• Text Entry	
• Save Prompt	
Home Screen Modes	17
• Printing Mode	18
• Densitometer Mode	21
• Calibration Mode	22
Settings	23
• Default Exposure	
• Default Step Size	

-
- Test Strip Mode
 - Enlarger Auto-Shutoff
 - Display Brightness
 - Buzzer Volume
 - Menu Timeout
-

Enlarger Configuration 25

- Enlarger List
 - Enlarger Settings
 - Timing Calibration
-

Safelight Configuration 30

Paper Profiles 32

- Introductory Theory
 - Profile List
 - Profile Properties
 - Grade Properties
 - Step Wedge Measurement
-

Step Wedge Properties 37

USB Peripherals 38

Updating Firmware 39

- Standard Update Procedure
 - Recovery Procedure
-

Regulatory Information 41

- Federal Communications Commission Notice
 - Industry Canada Compliance Statement
 - CE Declaration
 - UKCA Declaration
 - Equipment Information
-

Printalyzer Enlarging Timer User Manual

The Printalyzer Enlarging Timer & Exposure Meter is a timer for a darkroom enlarger. However, it is a lot more sophisticated than a simple clock. It is an “f-stop style” timer that adjusts time in stops of exposure, and also has sophisticated print metering capabilities.



Introduction

Dear Customer, Thank for for purchasing the Printalyzer Enlarging Timer.

At its core, this is a timer for darkroom enlargers. However, it is a lot more sophisticated than a simple clock. It is an “f-stop style” timer that adjusts time in stops of exposure, complete with support for test strips and dodging/burning. It also brings in sophisticated paper profiling and print metering capabilities.

It was designed to retain some of the features that made older timers good, such as a sturdy case and real clicky buttons, while also taking advantage of modern technology. It has fully upgradable firmware, a flexible interactive display, an expansion port for the control of non-traditional enlargers, and various peripheral ports.

Thanks,

Dektronics,Inc.



Safety Information

Intended Use

The Printalyzer Enlarging Timer is intended for the control of photographic enlargers and darkroom safelighting. With the included peripherals, it is also intended to be used for the metering of print exposures and the characterization of printing paper. As such, it has been designed to comply with the following safety standards:

- EN 61010-1:2010/A1:2019; IEC 61010-1:2010/AMD1:2016
- UL 61010-1:2012 R11.24
- CAN/CSA-C22.2 No 61010-1-12 R11.24

Symbols

Symbol	Description
	The general warning symbol indicates the possibility of damaging the instrument or compromising the results of a method
	The electrical hazard symbol indicates the presence of electrical components that can be harmful to the operator if handled incorrectly.
	Risk of fire

Safety Warnings



WARNING: Failure to follow these safety instructions could result in fire, electric shock, or other injury or damage to the product or other property. After reading this document carefully, keep it in a safe place for later reference.



WARNING: Ensure ground is reliably connected before plugging in the instruments power cord into the power source (receptacle).
Grounding is required to prevent electric shock. If the power source is not grounded, qualified personnel must first install a reliable safety ground.



CAUTION: Risk of electric shock. Do not open. No user serviceable parts.



WARNING: This device should only be used for the control of photographic enlargers and safelighting. Do not overload output sockets. Outlets have a combined rated load of 4.5A max.



WARNING: Only use your product with the power cord provided by the manufacturer.
Contact Dektronics Inc. for replacement should your power cord become missing or damaged. Use of a mains supply cord with inadequate rating may result in risk of fire.



WARNING: For continued protection against risk of fire, replace **ONLY** with a fuse of the specified type and rating.

 **Fuse: Rated, F5AH250V, 5x20mm**



WARNING: Power cord is used as the main disconnection device. To de-energize equipment, disconnect the power cord.



CAUTION: Protection may be impaired if used in a manner not specified by the manufacturer

Note: All Countries: Install product in accordance with local and National Electrical Codes

Technical Specifications

Voltage 100-240V ~

Frequency 50/60Hz

Current 5A Max

Mains Supply Fluctuations +/- 10%

Fuse Rating 250V, 5A, 5x20mm, High Breaking Capacity
F5AH250V

Over Voltage Category OVC II

Pollution Degree 2

Altitude Up to 2000m

Operating Temperature 5°C to 40°C (41°F to 104°F)

Storage Temperature -5°C to 85°C (23°F to 185°F)

Relative Humidity 5-95% non-condensing

Indoor Use Product is intended for indoor use only.

Wet Locations Product is not intended for wet locations

Ventilation Allow min of 1" from back of unit.

Socket-Outlet Loading

Max combined load of 4.5A total

Positioning for disconnection

Main AC inlet or plug is considered the main AC Disconnect. Always position the device so that the inlet or plug is accessible.

Device Overview

Major Components

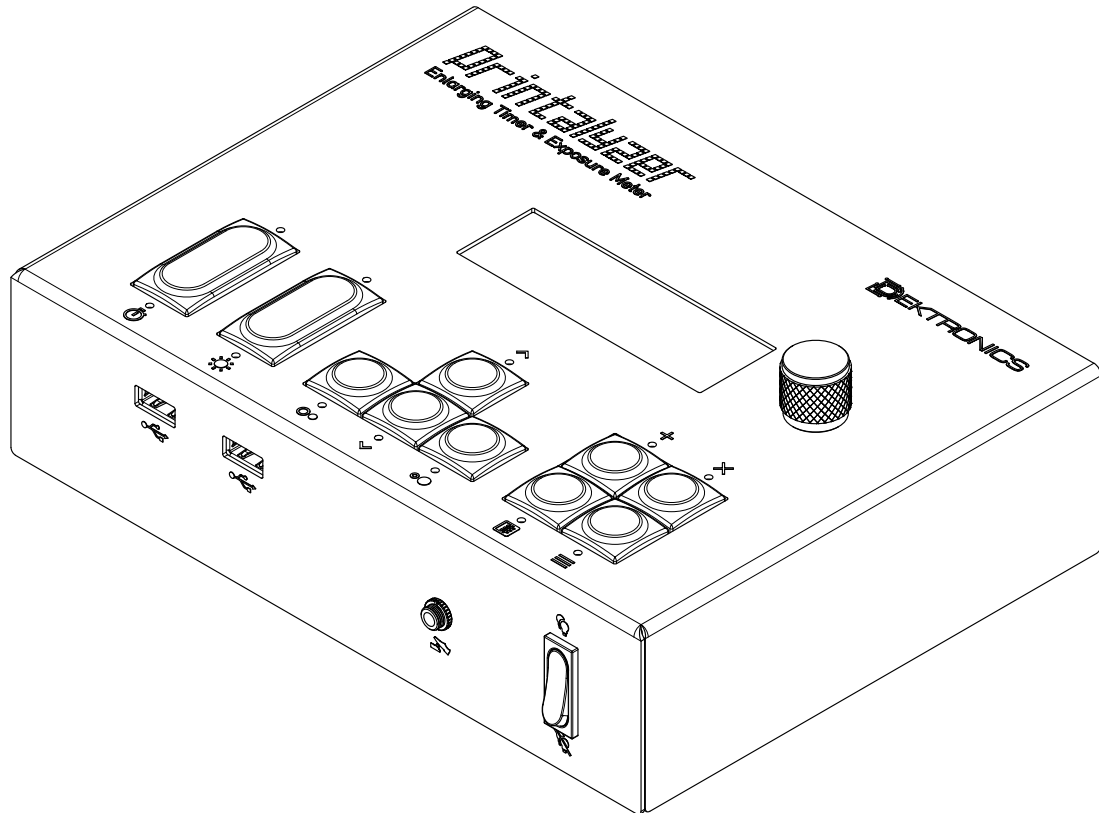

Fig. 1 Printalyzer Enlarging Timer

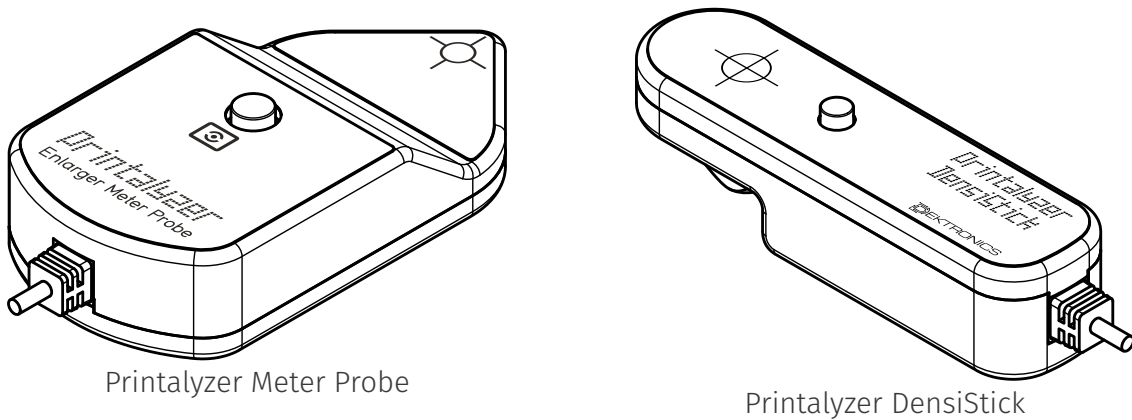
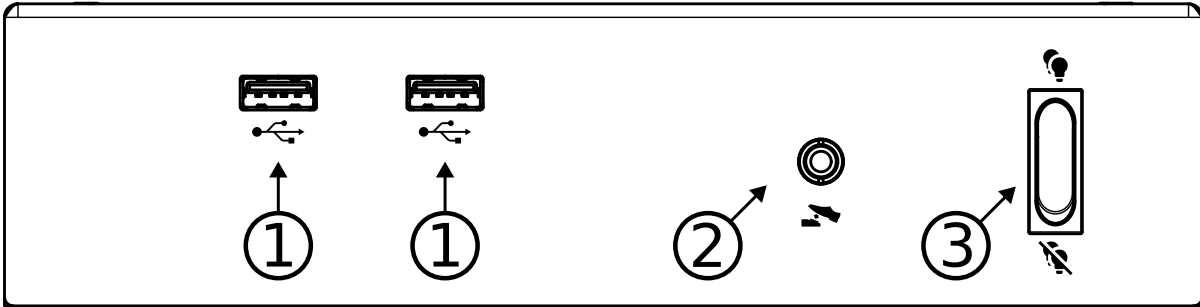

Fig. 2 Included Peripherals

Front Device Ports



①

USB Host port

This port is for connecting USB peripherals, such as the included Printalyzer Meter Probe, Printalyzer DensiStick, and other supported devices.

②

Footswitch port

This port is for connecting the included footswitch for hands-free exposure control.

③

Blackout switch

☑ Device and safelight illumination behaves normally.

☒ Device and safelight illumination is temporarily disabled for the safe handling of certain photographic materials.

Rear Device Ports

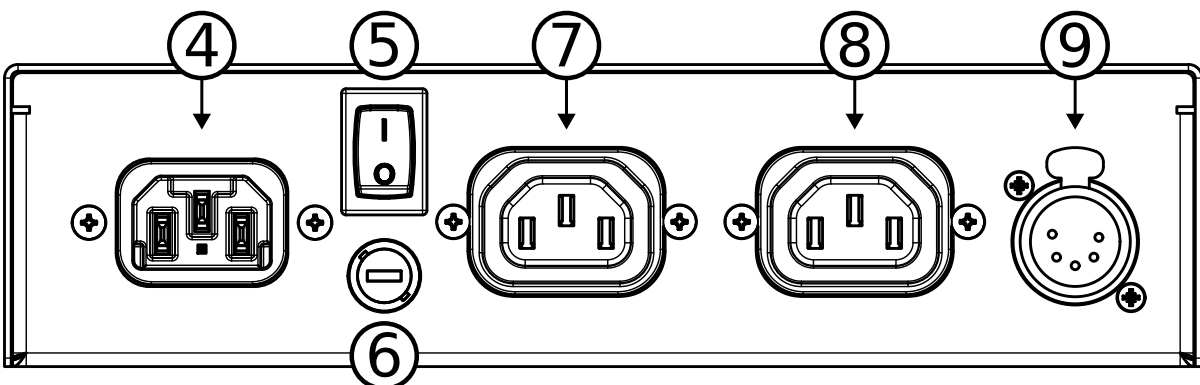

④

Power input port

Attach the power cord here.

5

Power switch

Toggle to turn the device on and off

6

Fuse

Protects the device against electrical faults.

Only replace with the proper fuse type, as specified in the safety information section.

7

Enlarger power port

Provides power to a photographic enlarger.

Use an IEC 320 C14 adapter or cord of suitable rating for your equipment.

8

Safelight power port

Provides power to darkroom safelighting.

Use an IEC 320 C14 adapter or cord of suitable rating for your equipment.

9

DMX512-compatible expansion port

Provides control signals for non-traditional enlargers and safelighting

Button Overview

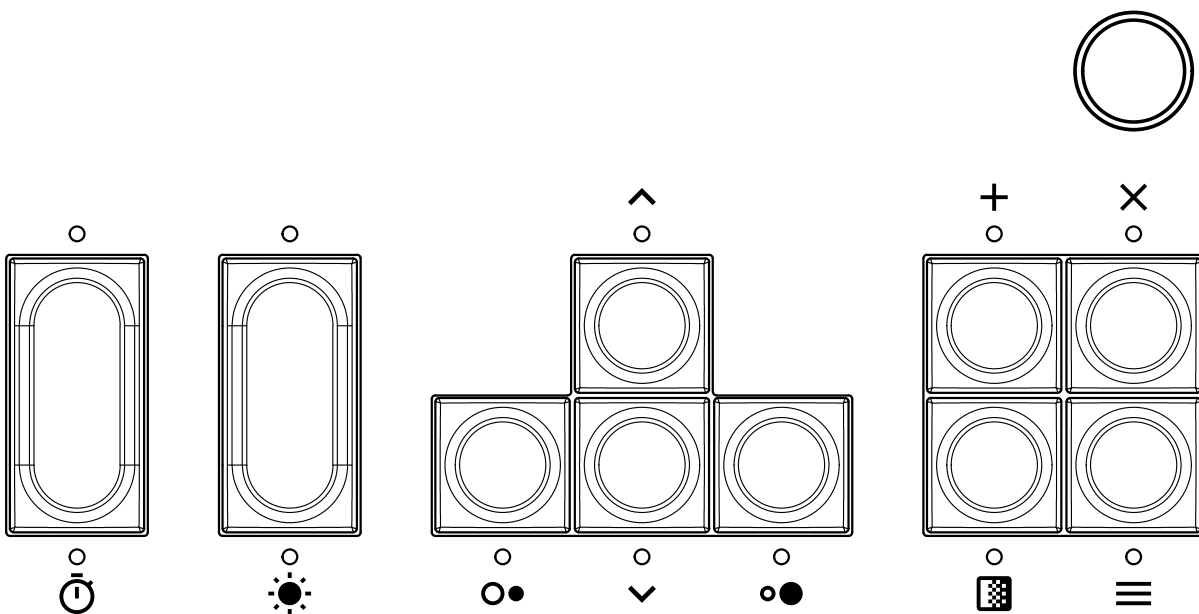



Start exposure



Focus mode



Decrease contrast; navigate left



Increase contrast; navigate right



Increase exposure time; navigate up



Decrease exposure time; navigate down



Add burn/dodge adjustment



Enter test strip mode



Cancel



Menu



Fine adjustment knob; also clickable

Menu Navigation

This section covers some basics of navigating the device menus, which should be common to most of the user interface. A few specific examples are shown, but the concepts should apply everywhere.

Main Menu

To get to the main menu, press the **≡** key from the home screen. The main menu is an example of an item list menu, which is the most common way of selecting an item from a list.



Fig. 3 Main Menu

When on one of these menus, you can typically perform the following actions:

- Press **^** or **v** to move up and down in the list
- Press **≡** to select the currently highlighted item
- Press **X** to leave the list menu

Number Entry

There are some screens used for entry of numbers. These come in many forms, but generally look something like this:

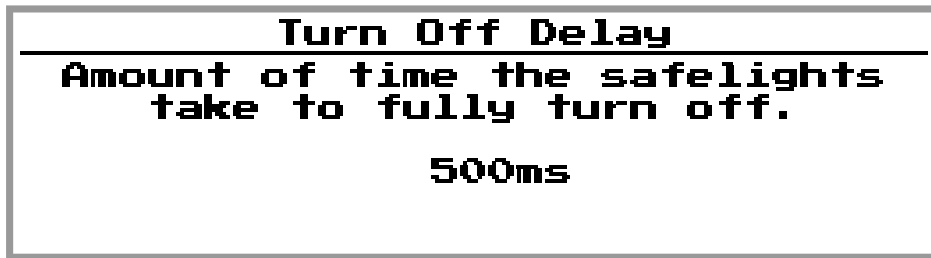

Fig. 4 Number Entry Screen

On one of these screens, you can typically perform the following actions:

- Press **▲** or **▼** to change the value by a small amount
- Press **○●** or **●●** to change the value by a larger amount
- Press **≡** to accept the new number value
- Press **✕** to leave without accepting the new number value

Text Entry

Various profile configurations let you enter a text description to better keep track of them. Text entry is a little more complicated, and is done through a screen like this:

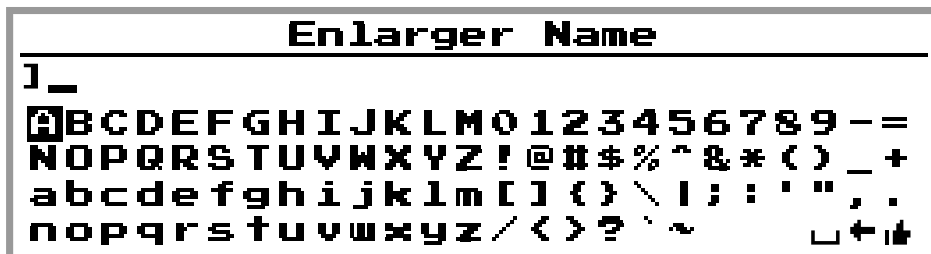

Fig. 5 Text Entry Screen

The actions for this screen are:

- Use **▲**, **▼**, **○●**, and **●●** as arrow keys to navigate around the letter grid
- Press **+** to add the currently highlighted letter or symbol
- The three symbols in the lower right corner are special, and perform different actions when pressing **+** for them. Specifically, they insert a space, remove the last character, and accept the input.
- Press **≡** as another way to accept the current input text

• Press **X** to leave without accepting the new text value

Another way to enter text is via an attached USB keyboard.

Save Prompt

On many screens, after making a change and pressing **X**, you will see a prompt like this:

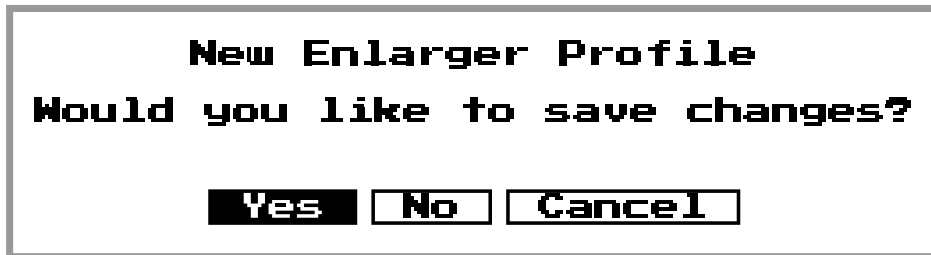







Fig. 6 Save Prompt

You can select “Yes” to accept the changes, “No” to reject them, or “Cancel” to return to the previous screen.

Home Screen Modes

These are the main home screen modes of the Printalyzer Timer. On power up the device starts in “Printing” mode, and this is the mode where you will spend the majority of your time while using the device.

To change modes, press the  and  buttons simultaneously and then release them. You can then use the  and  buttons individually to cycle through the various mode options. To select a mode, press the  button. To cancel mode selection, press .

Printing Mode

Printing Mode (sometimes called “B&W Printing Mode”) is the main mode of the Printalyzer Timer.

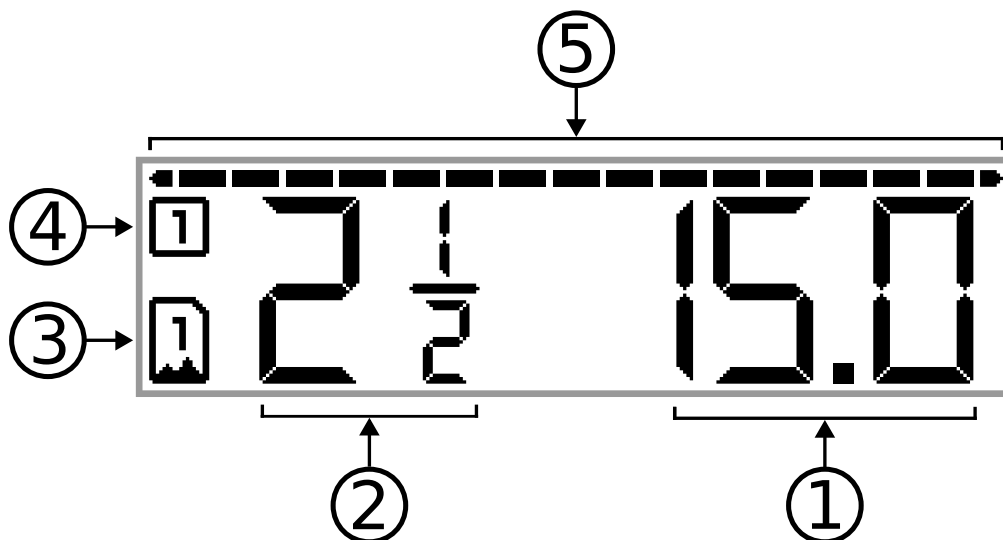

Fig. 7 Printing Mode Display

①

Exposure Time

The current print exposure time. If the exposure button is pressed, the enlarger will turn on for this number of seconds.

- 2 Contrast Grade**
The selected contrast grade used for calculating the tone graph. Depending on your enlarger configuration, a guide to color filter settings may appear below it. You still need to actually put the filtration corresponding to this number into your enlarger before performing a print exposure.
- 3 Paper Profile**
The selected paper profile, used in combination with the selected contrast grade for calculating the tone graph.
- 4 Burn/Dodge Areas**
The number of burn/dodge areas that have been configured for the current print.
- 5 Tone Graph**
The tone graph, which plots the meter readings taken for the current print.

Changing Stop Increment

To change the stop increment used for all functions in printing mode, simultaneously press the \wedge and \vee buttons and then release.



Fig. 8 Stop Increment Adjustment

You can then use the \wedge and \vee buttons individually to cycle through the choices, and press \times when finished.

Creating Test Strips

To create a test strip, press the  button to enter test strip mode.

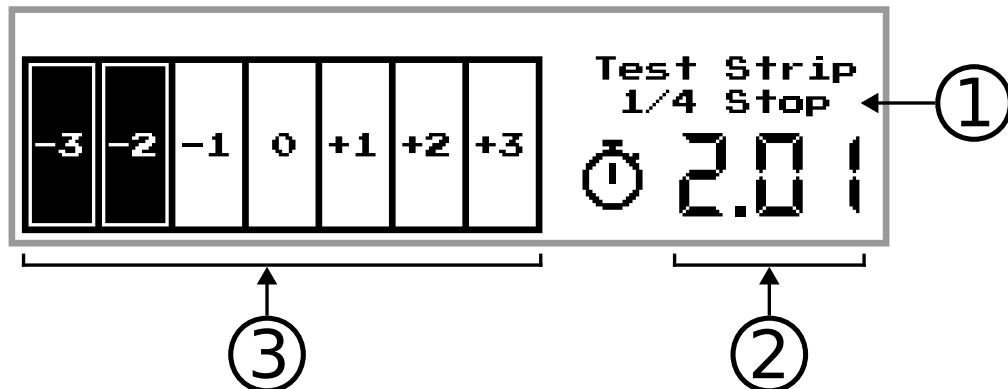

Fig. 9 Test Strip Creation Display

①

Stop Increment

The stop increment used for each subsequent patch of the test strip.

②

Next Exposure Time

The exposure time to be used for the next step of test strip creation.

③

Test Strip Overview

Shows the layout of the test strip, and which patches should be covered before the next exposure.

The number of patches in a test strip, and whether the strip is created using incremental or separate exposures, can be configured in the device settings menu.

Burn/Dodge Adjustments

To add a burn/dodge adjustment, press the **+** button. Long-press this button to see and modify the list of already-added burn/dodge adjustments.

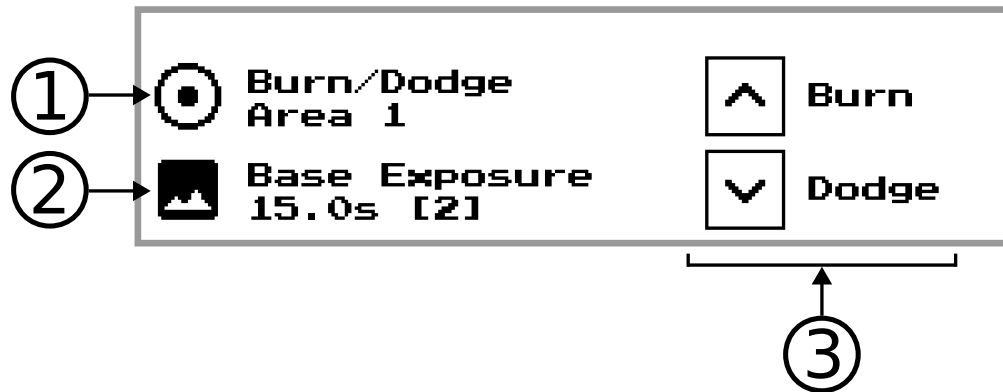

Fig. 10 Add Burn/Dodge Adjustment Display

①

Area to Add

The number of the next burn/dodge area to add, or the details of the area being added.

②

Base Exposure

The time and contrast grade for the base exposure.

③

Adjustment to Add

Press  to add a burn adjustment.

Press  to add a dodge adjustment.

Once pressed, this changes to show the stop increment being added or subtracted.

Densitometer Mode

Densitometer Mode is used to display density readings captured from incident light measurements or external densitometers.

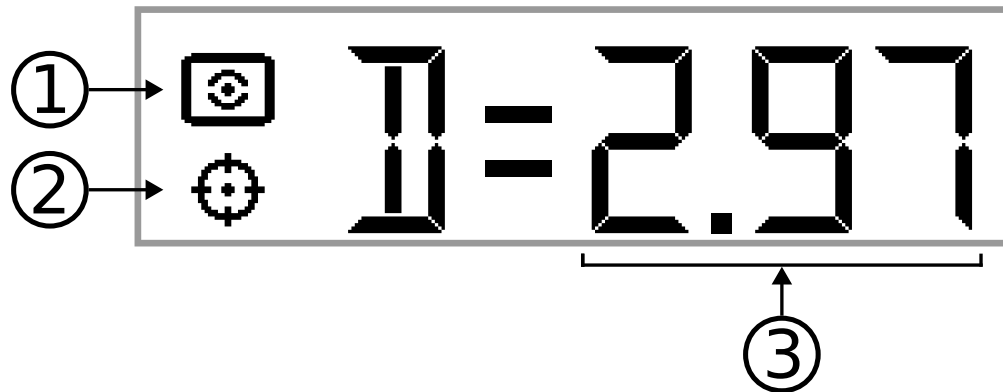

Fig. 11 Densitometer Mode Display

①

Incident Density

The displayed density reading is from measurements of a projected image taken with the Enlarger Meter Probe.

②

Transmission or Reflection Density

The displayed density reading is from an external transmission or reflection densitometer. The icon will change depending on the type of reading being displayed.

③

Density Reading

The most recent density reading for the current mode.

Calibration Mode

Calibration Mode is used to make test exposures for building paper profiles.

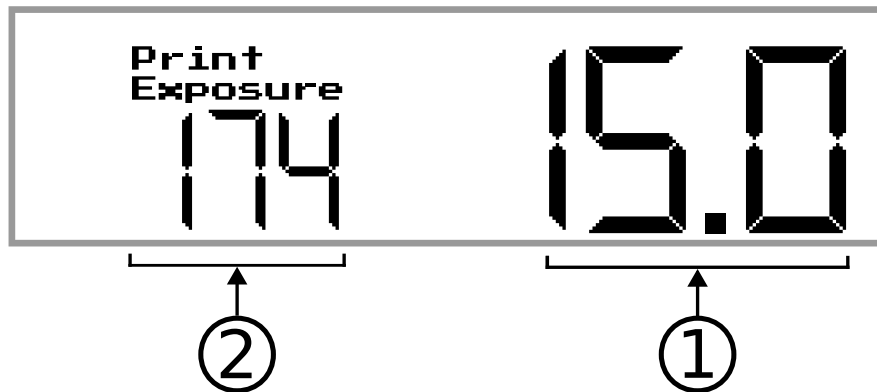

Fig. 12 Calibration Mode Display

①

Exposure Time

The current print exposure time. If the exposure button is pressed, the enlarger will turn on for this number of seconds.

②

Print Exposure Value

This value is captured with the Meter Probe and represents the amount of light the paper will receive when exposed. It is used for creating paper profiles.

Settings

Default Exposure

The exposure time and grade which will be shown on the home screen when the timer is initially powered on, or after its exposure state is cleared.

Default Step Size

The time adjustment increment, in stops, which will be used after the timer is initially powered on.

Test Strip Mode

The parameters to use when creating test strips. This includes the number of patches (5 vs 7) and whether test strips are created with incremental exposures or with a series of complete exposures.

Enlarger Auto-Shutoff

The amount of time after which the enlarger will automatically shut off, if it is left on in focus mode.

Display Brightness

The brightness of the main display and the panel lighting.

Buzzer Volume

The volume setting for the buzzer used to indicate various events.

Menu Timeout

The timeout after which the system will automatically leave any menus and return to the home screen.

Enlarger Configuration

Enlarger List

Enlarger Settings

Relay Control

The simplest and most traditional method of controlling a photographic enlarger is via relay control. This method simply switches power to the “Enlarger” outlet on the rear of the Printalyzer Enlarging Timer. Some enlargers use this as a direct power source for their lamp, while others use it as a control signal for their own power supplies.

The only additional setting in this mode is the “Contrast filters” setting. If set to “Regular,” then it is assumed that you will be using standard numbered contrast filters in the light path. If it is set to one of the other options, recommended equivalent settings for each contrast grade will also be shown on the device as a reference. This is especially useful when using the dichroic filter adjustments on a color enlarger in lieu of separate contrast filters.

DMX Control

For enlargers with non-traditional control mechanisms, a DMX512-compatible expansion port is provided by the Printalyzer Enlarging Timer. This allows interfacing to off-the-shelf DMX controlled LED drivers, as well as DMX controlled adapters that can be user provided for interfacing with a wide variety of manufactured and DIY enlargers.

The specific settings for this feature are still under development, especially in areas of value mapping and presets for contrast control and color printing. The options available here will be expanded over time alongside user needs and requests.

Enlarger Power Control	
Control method	[DMX]
DMX channel set	[RGB+W]
DMX resolution	[8-bit]
Channel IDs [1][2][3][4]	
Contrast control	[Green+Blue]
Focus brightness	[255]
Safe (Red) brightness	[255]
Exposure brightness	[...]
Contrast grades	[...]

Fig. 13 Enlarger DMX Control Parameters

Parameter	Description
DMX channel set	<p>White - Single white light channel</p> <p>RGB - Separate red, green, and blue channels</p> <p>RGB+W - Separate red, green, blue, and white channels</p>
DMX resolution	<p>8-bit - Single channel ID per light color, giving a value range of 0-255</p> <p>16-bit - Two adjacent channel IDs per light color, giving a value range of 0-65535</p> <p><i>Note: 16-bit control is highly recommended, if your hardware can support it, as it allows for much finer adjustments with contrast control and color printing.</i></p>
Channel IDs	The DMX channel IDs corresponding to each light color
Contrast control	<p>None - Printing will always use white (or white-equivalent) light, expecting contrast to be controlled via external filters</p> <p>Green+Blue - Printing will use a configurable mixture of green and blue light colors to achieve each contrast grade</p>
Focus brightness	Brightness value used for the white (or white-equivalent) light when in focus mode
Safe (Red) brightness	<p>Brightness value used for the red light when the enlarger is on but not exposing paper</p> <p><i>(This feature is only shown if your enlarger has a red light source, and is intended to be used as a convenience feature in-between test strip and burn/dodge exposures.)</i></p>

Parameter	Description
Exposure brightness	Brightness value used to comprise the white (or white-equivalent) light used for print exposure without internal contrast control <i>(This feature is only shown with the “White” channel set or the “None” contrast control setting)</i>
Contrast grades	Red/Green brightness values used for each contrast grade <i>(This feature is only shown if the channel set includes green and blue, and contrast control is set to “Green+Blue”)</i>

Timing Calibration

Photographic enlargers are not instantaneous sources of light. They always take some amount of time to turn on and off. The amount of time can vary dramatically depending on what sort of lamp the enlarger uses, and how that lamp is controlled. Some enlargers respond very quickly, while others do not.

The Printalyzer Enlarging Timer has the ability to characterize and compensate for this behavior. By taking this extra step, accuracy and repeatability of exposures can be dramatically improved. The impact of this is especially noticeable on short exposures, such as with incremental test strips and burn/dodge adjustments.

The following graph illustrates the events that occur during an exposure, thus illustrating the problem:

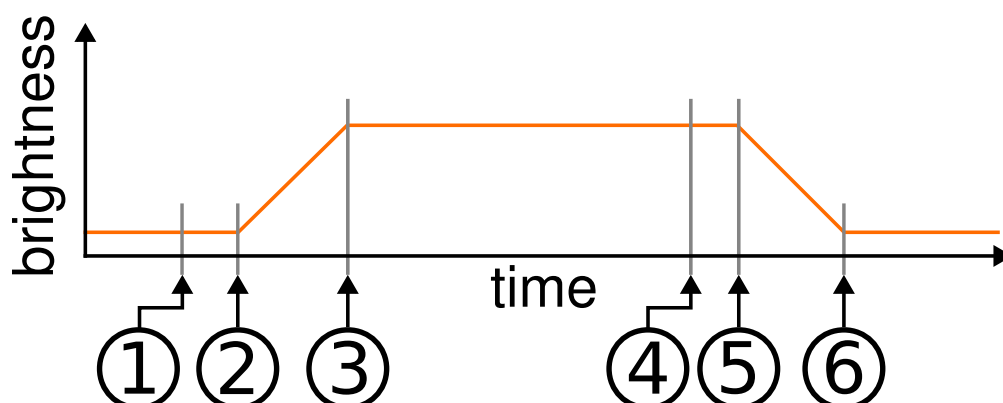

Fig. 14 Enlarger Brightness Timeline

- ① Turn On Event**
The enlarger is commanded to turn on, by either toggling the control relay or via a DMX signal
- ② Brightness Rising**
The enlarger light begins turning on
- ③ Full Brightness**
The enlarger light has reached full intensity
- ④ Turn Off Event**
The enlarger is commanded to turn off, by either toggling the control relay or via a DMX signal
- ⑤ Brightness Falling**
The enlarger light begins turning off
- ⑥ Enlarger Completely Off**
The enlarger is completely dark

To characterize this behavior for better exposures, several parameters are measured and stored as a “timing profile” within the enlarger’s configuration. These parameters are as follows:

Enlarger Timing Profile	
Turn on delay	[88ms]
Rise time	[528ms]
Rise time equivalent	[317ms]
Turn off delay	[13ms]
Fall time	[504ms]
Fall time equivalent	[55ms]

Fig. 15 Enlarger Timing Parameters

Parameter	Description
-----------	-------------

Turn on delay	The time from when the enlarger is commanded to turn on until the light level starts to rise
----------------------	--

Parameter	Description
Rise time	The time from when the light level starts to rise until it reaches full brightness
Rise time equivalent	The duration of full brightness enlarger light that would produce an equivalent exposure to the rise period
Turn off delay	The time from when the enlarger is commanded to turn off until the light level starts to fall
Fall time	The time from when the light level starts to fall until the enlarger is completely off
Fall time equivalent	The duration of full brightness enlarger light that would produce an equivalent exposure to the fall period

While these parameters can be set manually, they are typically set via the enlarger timing calibration process. To perform the timing calibration, do as follows:

- Adjust the enlarger head to maximize brightness
 - Select the “Test Enlarger” menu option on the enlarger configuration screen and turn on the enlarger
 - Lower the head to a height similar to what you would use for a 5x7” print
 - Fully open the lens aperture
 - Roughly focus the enlarger
 - Turn off the enlarger
- Make sure the Meter Probe is connected and place its sensor in the middle of the frame
- Select “Calibrate Timing” and follow the prompts

This process will then run the enlarger through a series of automated on/off cycles while measuring its light output, and calculate the timing profile.

Safelight Configuration

Safelight Configuration	
Safelight mode	[Auto]
Power control	[Relay+DMX]
DMX address	[5]
DMX resolution	[8-bit]
DMX brightness value	[255]

Fig. 16 Safelight Configuration Parameters

Parameter	Description
Safelight mode	<p>Off - Safelight is normally off</p> <p>On - Safelight is normally on, but turned off when the enlarger is on</p> <p>Auto - Safelight is normally on, but turned off when taking meter readings and during print exposures</p>
Turn off delay	Amount of time to wait, after commanding the safelights to shut off, before it is safe to take readings with the meter probe. This is to compensate for the fact that safelights do not respond instantly, and it may need to be adjusted to find the ideal value.
Power control	<p>Relay - Safelight controlled via the relay switched outlet</p> <p>DMX - Safelight controlled via DMX</p> <p>Relay+DMX - Safelights controlled via both the relay switched outlet and DMX</p>
DMX address	The DMX channel ID corresponding to the safelight (Only shown when DMX safelight control is enabled)
DMX resolution	<p>8-bit - Single channel ID for the safelight, giving a value range of 0-255</p> <p>16-bit - Two adjacent channel IDs for the safelight, giving a value range of 0-65535</p> <p>(Only shown when DMX safelight control is enabled)</p>
DMX brightness value	Brightness value used for turning on the safelight (Only shown when DMX safelight control is enabled)

Paper Profiles

Introductory Theory

Printing paper profiles attempt to capture the characteristic curve of photographic printing paper, as it is defined in ISO 6846:1992(E). This curve represents the relationship between light exposure, on a logarithmic scale, and visual reflection density of the resulting processed paper.

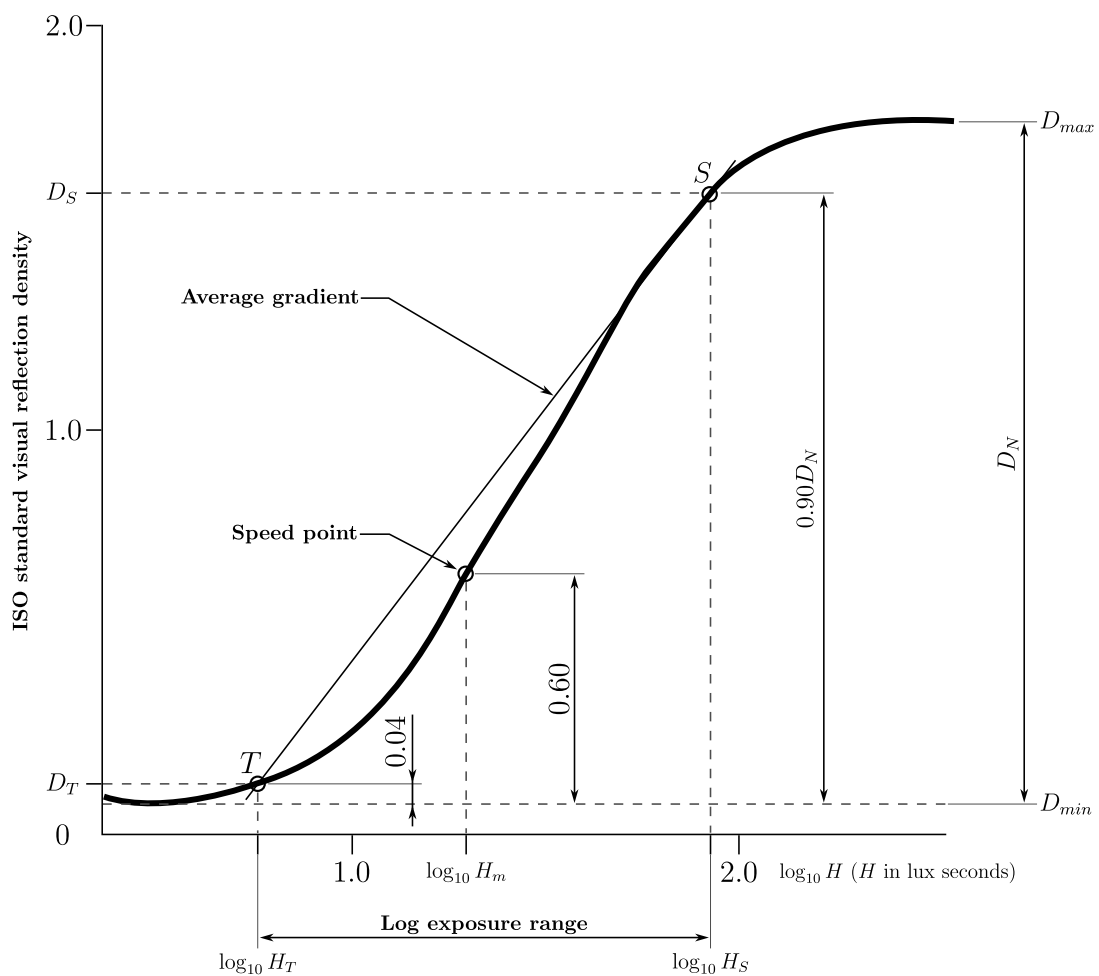

Fig. 17 Printing Paper Sensitometric Curve

The curve itself is defined by the following parameters, which are captured within the paper profile settings:

Parameter	Description
D_{min}	Minimum density of the printing paper
D_{max}	Maximum density of the printing paper
$\log_{10} H_T$	Light exposure to produce a density of $D_{min} + 0.04$, which is 0.04 above the paper base
$\log_{10} H_m$	Light exposure to produce a density of $D_{min} + 0.60$, which is 0.60 above the paper base and otherwise known as the “speed point” of the paper
$\log_{10} H_S$	Light exposure to produce a density of $0.90 \cdot D_N$, which is 90% of the paper’s max net density. The max net density is defined as $D_N = D_{max} - D_{min}$.
$ISO(R)$	The paper’s contrast range, which is defined as: $R = 100 \cdot (\log_{10} H_S - \log_{10} H_T)$

For all the above parameters, the light value H is in lux-seconds. Within individual printing profiles, and the entire profile calibration process, a unit called the **PEV** (“Print Exposure Value”) is used. It is defined as $PEV = 100 \cdot \log_{10} H$ which is effectively the same unit that is used as the basis for $ISO(R)$. It was chosen as a compact, convenient, and user friendly way of encapsulating an amount of light paper is exposed to.

Because most photographic printing papers are now multigrade, each filtered contrast grade has its own characteristic curve and thus requires a separate set of H numbers.

Profile List

Paper Profiles	
<01>	Ilford MGRC
[02]	Ilford MGFB
[03]	Foma Fomaspeed 313 VC RC
[04]	Adox MCC 110
*** Add New Profile ***	

Fig. 18 Paper Profile List

On the list of paper profiles, each profile has a number. The currently active profile is denoted by its number being surrounded by angle brackets (i.e. "<01>"), and its number is also shown in an icon on the home screen.

To change the currently active profile, highlight a profile and press the **+** button.

Profile Properties

Paper Profile 1		
Name	[Ilford MGRC]	
Paper Dmin	[D=0.08]	
Paper Dmax	[D=2.02]	
Grade 00	[14]	[---] [179]
Grade 0	[19]	[---] [144]

Fig. 19 Paper Profile Properties

The top level properties of a paper profile consist of the following:

Name	Name of the profile, used for reference within the menus
Paper Dmin	The minimum density of the paper, otherwise known as the density of the paper base
Paper Dmax	The maximum density of the paper
Grade 00..5	<p>The profile settings for each grade, which are shown as three numbers:</p> <p>$D_{min} + 0.04$ in PEV units</p> <p>$D_{min} + 0.60$ in PEV units</p> <p>$ISO(R)$, the paper's contrast range</p> <p><i>Selecting this item will take you to a screen for setting grade-specific properties.</i></p>

Grade Properties

```

Ilford MGRC Grade 2
Base exposure (Dmin+0.04) [ 54]
Speed point (Dmin+0.60) [ 97]
ISO Range [ 87]
*** Measure From Step Wedge ***
*** Accept Changes ***

```

Fig. 20 Paper Profile Grade Properties

Base exposure $D_{min} + 0.04$ in PEV units

Speed point $D_{min} + 0.60$ in PEV units

ISO Range $ISO(R)$, which is the contrast range of the paper

Measure From Step Wedge Launches a utility for calculating these numbers from the density measurement of a step wedge exposure

Step Wedge Measurement

```

Ilford MGRC Grade 2
Step wedge (Stouffer T1415)
Paper Dmin (D=0.08)
Paper Dmax (D=2.02)
Paper Exposure Value [148]
Step 1 (D=0.03) [D=1.92]
Step 2 (D=0.18) [D=1.56]
Step 3 (D=0.32) [D=1.13]
Step 4 (D=0.47) [D=0.76]
Step 5 (D=0.61) [D=0.50]
Step 6 (D=0.76) [D=0.30]
Step 7 (D=0.91) [D=0.14]
Step 8 (D=1.06) [D=0.08]
Step 9 (D=1.21) [D=0.08]
Step 10 (D=1.35) [D=0.08]
Step 11 (D=1.50) [D=0.08]
Step 12 (D=1.66) [D=0.08]
Step 13 (D=1.81) [D=0.08]
Step 14 (D=1.97) [D=0.08]
*** Calculate Profile ***

```

Fig. 21 Step Wedge Exposure Measurement

Step wedge Name of the configured step wedge used for the exposure

Paper Dmin The minimum density of the paper, shown for reference

Paper Dmax The maximum density of the paper, shown for reference

Step 1..N The measurements of each patch of the step wedge, as exposed onto the printing paper:
 The first number is the density of the step wedge patch itself, shown for reference.
 The second number is the measurement of the area of paper onto which this patch has been exposed.
 These two columns of numbers should run in oppose directions.

Calculate Profile Performs calculations based on the above data

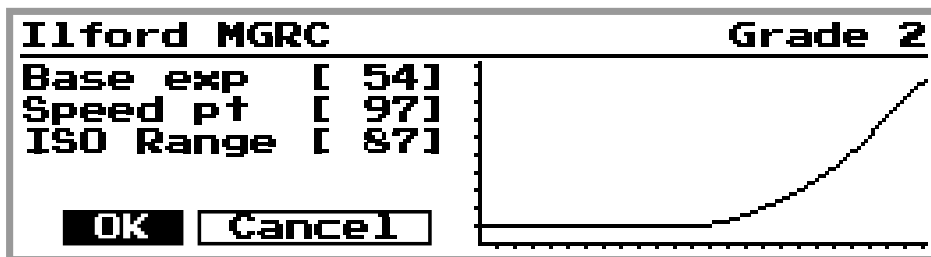

Fig. 22 Step Wedge Exposure Calculation

This shows the results of profile calculation, along with a graph of the paper's characteristic curve. Select **OK** to accept these values.

Step Wedge Properties

USB Peripherals

The Printalyzer Enlarging Timer supports a variety of peripheral devices via the USB Host ports on its front.

The supported devices include:

- Printalyzer Meter Probe (included peripheral for enlarger baseboard metering)
- Printalyzer DensiStick (included peripheral for reflection density measurement)
- Keyboards (for ease of text entry)
- USB Flash Drives (for installing firmware updates and configuration import/export)
- Densitometers
 - Direct USB interface
 - Printalyzer Densitometer (DPD-100)
 - Printalyzer UV/VIS Densitometer (DPD-105)
 - Heiland TRD-2
 - Tobias TBX series
 - USB-to-Serial adapter
 - X-Rite 800 series
 - Supported adapter chipsets: CH34x, CP210x, FTDI, PL2303
- USB Hubs (limited to one level)

Updating Firmware



The Printalyzer Enlarging Timer is designed to have firmware that can be updated. This is so that features can be added, and bugs can be fixed, after the device has shipped. The update process is designed to be relatively straightforward.

To update the device firmware, you will need:

- The Printalyzer Enlarging Timer itself
- The latest firmware file
- A FAT32-formatted USB flash drive

Standard Update Procedure

The update procedure is as follows:

- Download the appropriate firmware file to your computer
- Using your computer, copy the firmware file to a FAT32-formatted USB flash drive
- Safely unmount/eject and remove the USB flash drive
- Unplug any peripherals from the USB ports on the front of the Printalyzer Enlarging Timer
- Insert the USB flash drive into one of the USB ports on the front of the Printalyzer Enlarging Timer
- Press the  button, navigate down to the “Update Firmware” menu item, and press  again
- Select the firmware file you want to install, and press 
- Review the prompt, which will show the current and new firmware versions. If these look correct, select “YES” to continue.



The Printalyzer Enlarging Timer will now restart, install the new firmware version, and then restart again. There will be on-screen graphics showing the progress of this process.

Recovery Procedure

Note

Before assuming that the Printalyzer Enlarging Timer is not able to start correctly, please make sure that the Blackout Switch is in the  position.

In case the firmware update fails, and/or the Printalyzer Enlarging Timer is not able to start correctly, there is a recovery procedure:

- Download the appropriate firmware file to your computer and rename it to `DPD500FW.BIN`
- Using your computer, copy the `DPD500FW.BIN` file to a FAT32-formatted USB flash drive
- Safely unmount/eject and remove the USB flash drive
- Make sure the Printalyzer Enlarging Timer is turned off, and unplug any USB peripherals
- Insert the USB flash drive into one of the USB ports on the front of the Printalyzer Enlarging Timer
- While holding down the  button, turn on the Printalyzer Enlarging Timer
- Wait a few seconds, then release the  button

The Printalyzer Enlarging Timer will install `DPD500FW.BIN` as the new firmware version, and then restart again. There will be on-screen graphics showing the progress of this process.

Regulatory Information

Federal Communications Commission Notice



Note: This equipment has been tested and found to comply with the limits for a Class B digital device, pursuant to part 15 of the FCC Rules. These limits are designed to provide reasonable protection against harmful interference in a residential installation. This equipment generates, uses and can radiate radio frequency energy and, if not installed and used in accordance with the instructions, may cause harmful interference to radio communications. However, there is no guarantee that interference will not occur in a particular installation. If this equipment does cause harmful interference to radio or television reception, which can be determined by turning the equipment off and on, the user is encouraged to try to correct the interference by one or more of the following measures:

- Reorient or relocate the receiving antenna.
- Increase the separation between the equipment and receiver.
- Connect the equipment into an outlet on a circuit different from that to which the receiver is connected.
- Consult the dealer or an experienced radio/TV technician for help.

Industry Canada Compliance Statement

CAN ICES-003(B) / NMB-003(B)

CE Declaration



Hereby, Dektronics, Inc, declares that the Printalyzer UV/VIS Densitometer DPD-105 has been tested and is fully compliant with the EU EMC Directive 2014/30/EU.

UKCA Declaration



Hereby, Dektronics, Inc, declares that the Printalyzer UV/VIS Densitometer DPD-105 has been tested and is fully compliant with the UK EMC Regulations (2016).

Equipment Information

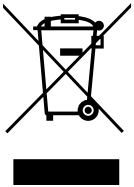

Instructions for disposal: Please dispose of Waste Electrical and Electronic Equipment (WEEE) at designated collection points for the recycling of such equipment.

